

2" SC SPACER 0-1" LOWER ASSEMBLY INSTRUCTIONS

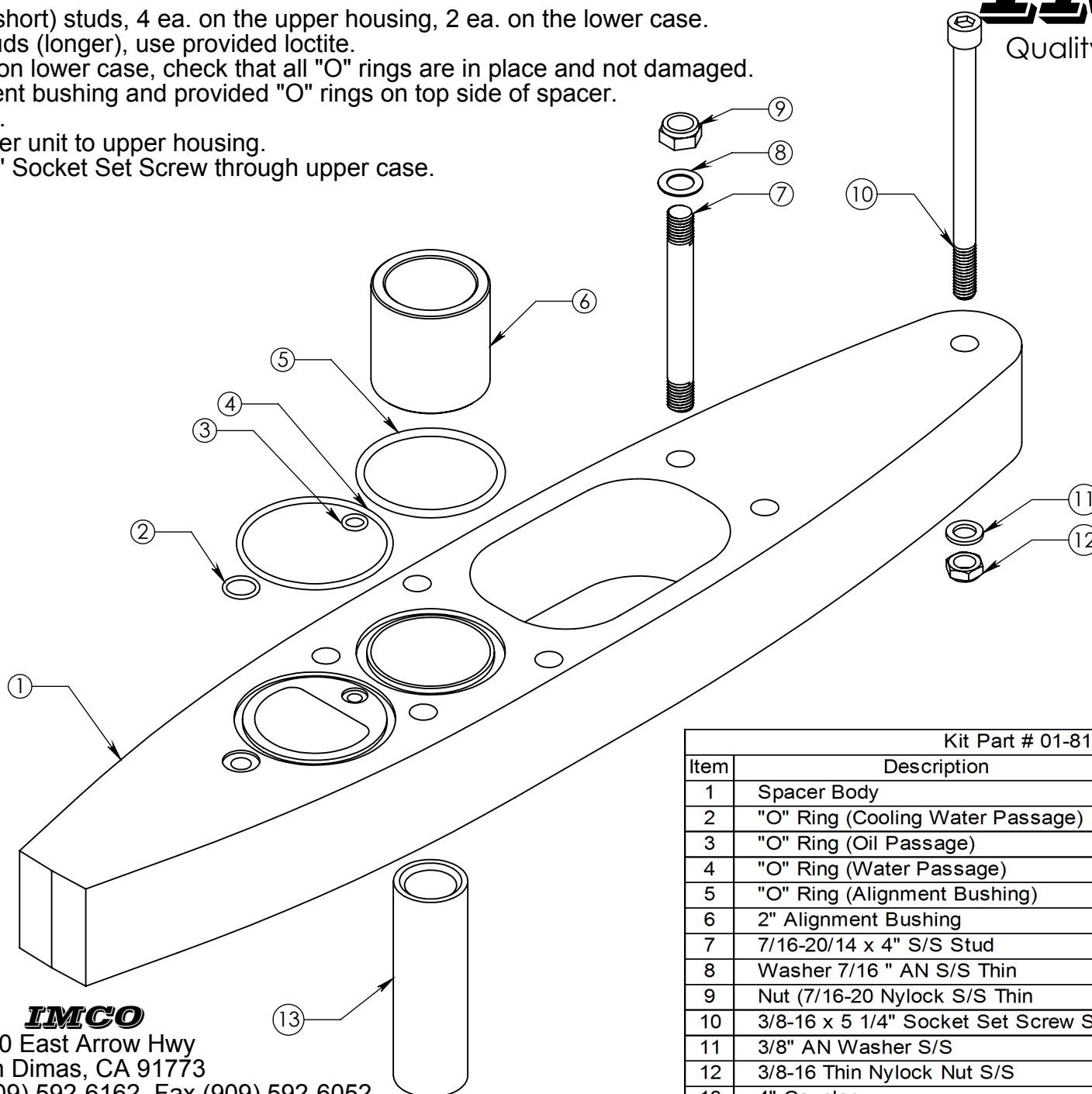

Quality Marine Products

1. Remove old (short) studs, 4 ea. on the upper housing, 2 ea. on the lower case.
2. Install new studs (longer), use provided loctite.
3. Place spacer on lower case, check that all "O" rings are in place and not damaged.
4. Install alignment bushing and provided "O" rings on top side of spacer.
5. Install coupler.
6. Assemble lower unit to upper housing.
7. Assemble 3/8" Socket Set Screw through upper case.
7. Tighten nuts.



Kit Part # 01-8107			
Item	Description	Qty	Part Number
1	Spacer Body	1	01-7017
2	"O" Ring (Cooling Water Passage)	1	11-2014
3	"O" Ring (Oil Passage)	1	11-4011
4	"O" Ring (Water Passage)	1	11-2143
5	"O" Ring (Alignment Bushing)	1	11-2228
6	2" Alignment Bushing	1	01-2278
7	7/16-20/14 x 4" S/S Stud	6	08-130904201
8	Washer 7/16 " AN S/S Thin	6	08-160900001
9	Nut (7/16-20 Nylock S/S Thin	6	08-090904001
10	3/8-16 x 5 1/4" Socket Set Screw S/S	1	08-050806251
11	3/8" AN Washer S/S	1	08-100800001
12	3/8-16 Thin Nylock Nut S/S	1	08-090806001
13	4" Coupler	1	01-2169
14	Loctite	1	

IMCO
 510 East Arrow Hwy
 San Dimas, CA 91773
 (800) 899-8058 (909) 592-6162 Fax (909) 592-6052
 info@imcomarine.com www.imcomarine.com