

# 1/2" SC SPACER 0-1" LOWER ASSEMBLY INSTRUCTIONS

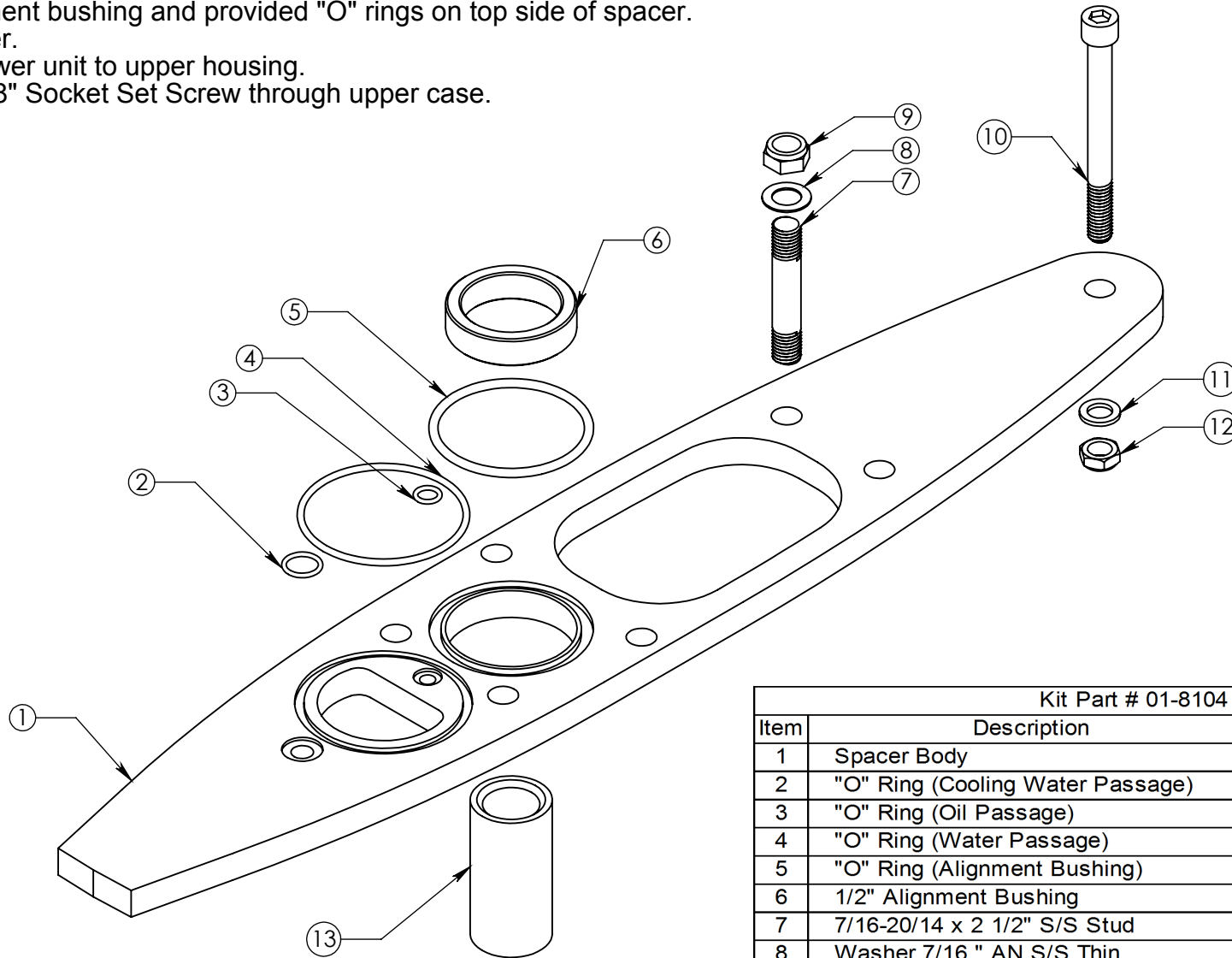

1. Remove old (short) studs, 4 ea. on the upper housing, 2 ea. on the lower case.
2. Install new studs (longer), use provided loctite.
3. Place spacer on lower case, check that all "O" rings are in place and not damaged.
4. Install alignment bushing and provided "O" rings on top side of spacer.
5. Install coupler.
6. Assemble lower unit to upper housing.
7. Assemble 3/8" Socket Set Screw through upper case.
7. Tighten nuts.



Kit Part # 01-8104			
Item	Description	Qty	Part Number
1	Spacer Body	1	01-7014
2	"O" Ring (Cooling Water Passage)	1	11-2014
3	"O" Ring (Oil Passage)	1	11-4011
4	"O" Ring (Water Passage)	1	11-2143
5	"O" Ring (Alignment Bushing)	1	11-2228
6	1/2" Alignment Bushing	1	01-2275
7	7/16-20/14 x 2 1/2" S/S Stud	6	08-130904141
8	Washer 7/16 " AN S/S Thin	6	08-160900001
9	Nut (7/16-20 Nylock S/S Thin	6	08-090904001
10	3/8-16 x 3 3/4" Socket Set Screw S/S	1	08-050806191
11	3/8" AN Washer S/S	1	08-100800001
12	3/8-16 Thin Nylock Nut S/S	1	08-090806001
13	2 1/2" Coupler	1	01-2168
14	Loctite	1	

**IMCO**

510 East Arrow Hwy  
San Dimas, CA 91773

(800) 899-8058 (909) 592-6162 Fax (909) 592-6052  
info@imcomarine.com www.imcomarine.com