

1/2" SC SPACER 2" LOWER ASSEMBLY INSTRUCTIONS

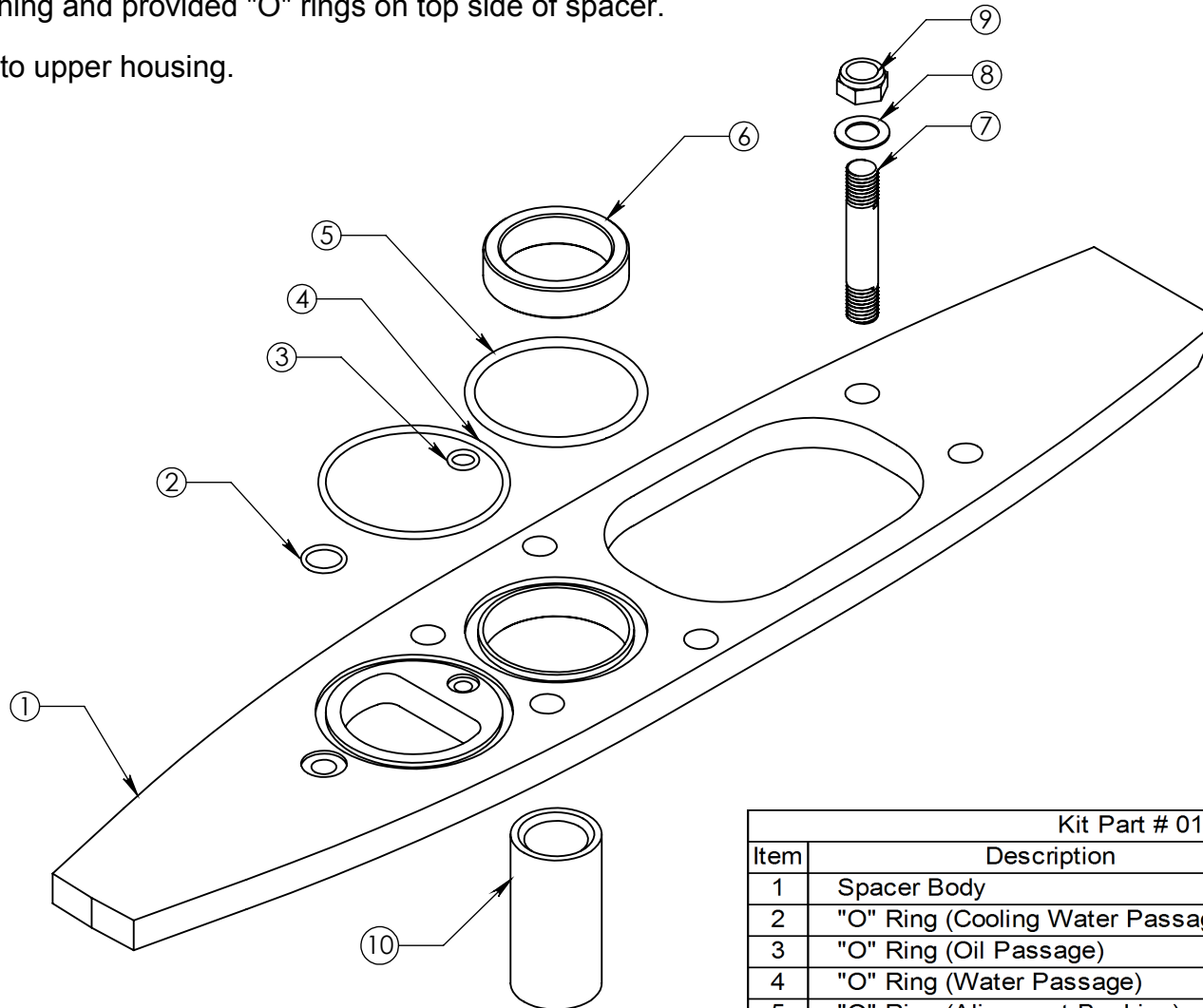

1. Remove old (short) studs, 4 ea. on the upper housing, 2 ea. on the lower case.
2. Install new studs (longer), use provided loctite.
3. Place spacer on lower case, check that all "O" rings are in place and not damaged.
4. Install alignment bushing and provided "O" rings on top side of spacer.
5. Install coupler.
6. Assemble lower unit to upper housing.
7. Tighten nuts.



Kit Part # 01-8100			
Item	Description	Qty	Part Number
1	Spacer Body	1	01-7010
2	"O" Ring (Cooling Water Passage)	1	11-2014
3	"O" Ring (Oil Passage)	1	11-4011
4	"O" Ring (Water Passage)	1	11-2143
5	"O" Ring (Alignment Bushing)	1	11-2228
6	1/2" Alignment Bushing	1	01-2275
7	7/16-20/14 x 2 1/2" S/S Stud	6	08-130904141
8	Washer 7/16 " AN S/S Thin	6	08-160900001
9	Nut (7/16-20 Nylock S/S Thin	6	08-090904001
10	2 1/2" Coupler	1	01-2168
11	Loctite	1	

IMCO

510 East Arrow Hwy
San Dimas, CA 91773

(800) 899-8058 (909) 592-6162 Fax (909) 592-6052
info@imcomarine.com www.imcomarine.com