

# 2" SCX4 SPACER 01-8060 ASSEMBLY INSTRUCTIONS

1. Remove old (short) studs, 6 ea. on the upper housing, 2 ea. on the lower case.
2. Install new studs (longer), use provided loctite.
3. Place spacer on lower case, check that all "O" rings are in place and not damaged.
4. Install alignment spacer and provided "O" rings on top side of spacer.
5. Install coupler.
6. Assemble lower unit to upper housing.
7. Tighten nuts.

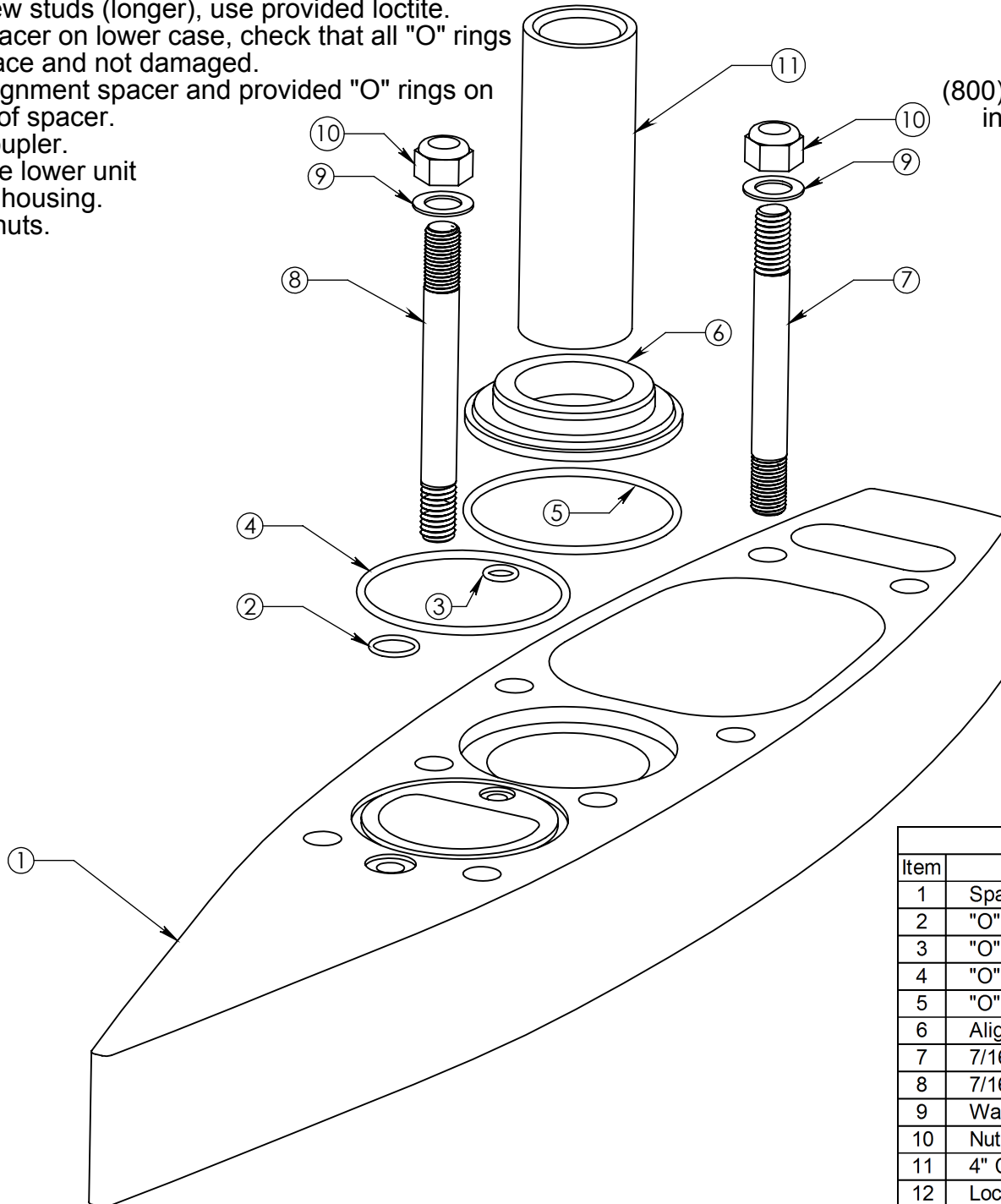

# IMCO

Quality Marine Products

510 East Arrow Hwy

San Dimas, CA 91773

(800) 899-8058 (909) 592-6162 Fax (909) 592-6052

info@imcomarine.com www.imcomarine.com

Kit Part # 01-8060			
Item	Description	Qty	Part Number
1	Spacer Body	1	01-2461
2	"O" Ring (Cooling Water Passage)	1	11-2014
3	"O" Ring (Oil Passage)	1	11-4011
4	"O" Ring (Water Passage)	1	11-2143
5	"O" Ring (Alignment Spacer)	1	11-2144
6	Alignment Spacer	1	01-2401
7	7/16-20/14 x 4" S/S Stud	6	08-130904201
8	7/16-20/14 x 4 1/8" S/S Stud	2	08-130904821
9	Washer 7/16 " AN S/S	8	08-100900001
10	Nut 7/16-20 Nylock S/S	8	08-080904001
11	4" Coupler	1	01-2146
12	Loctite	1	09-2038